

Pasos / Steps / Mesures / Passos

1 Colocar el carro y el tope en la guía

EN Put the upper wheel and damping stopper into the rail
 FR Placez la roue supérieure et la butée d'amortissement dans la rail
 PT Coloque a roda superior e o batente de amortecimento no carril

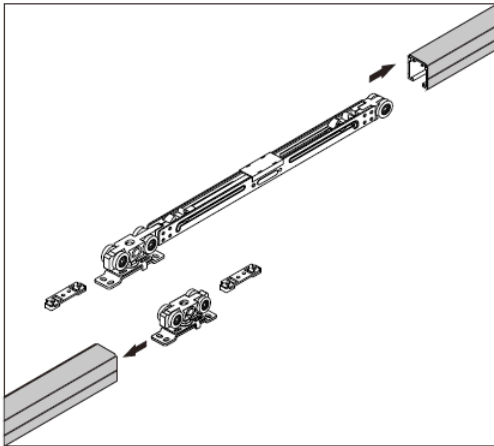

2 Fijar la guía superior y el guiador de suelo

EN Fix the upper rail and floor guide
 FR Fixer le rail supérieur et le guide au sol
 PT Fixe o carril superior e a guia de piso

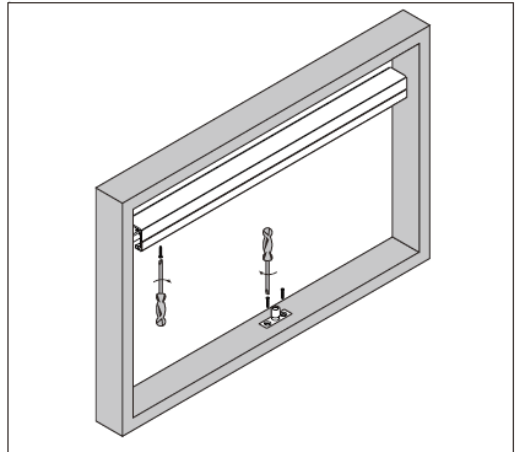

3 Ajustar el soporte de acuerdo a la anchura de la puerta

EN Adjust the bracket according door width
 FR Ajustez le support en fonction de la largeur de la porte
 PT Ajuste o suporte de acordó com a largura da porte

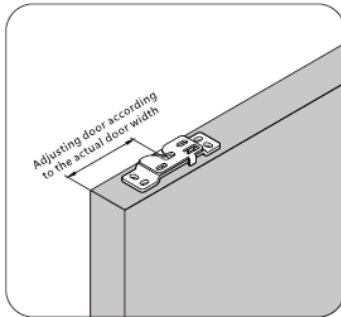

4 Instalar el soporte

EN Install the bracket
 FR Installer le support
 PT Instale o suporte

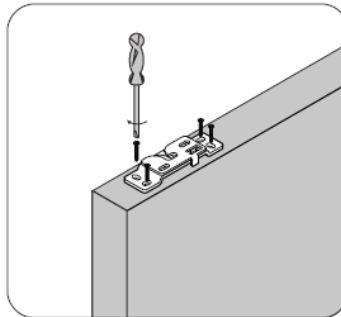

5 Colgar la puerta

EN Hang the door on
 FR Accrocher la porte
 PT Pendura a porta

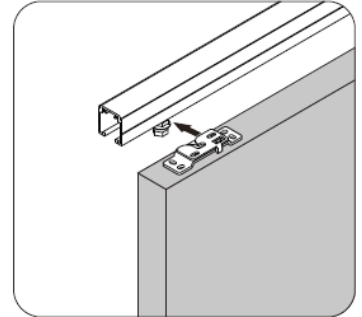

Parámetros de instalación

EN Installation parameter
 FR Paramètre d'installation
 PT Parâmetro de instalação

Altura de la puerta (h) = Hueco de puerta (H) - 72mm
 Door Height (h) = Door gap (H) - 72 mm
 Hauteur de la porte (h) = Espace de porte - 72mm
 Altura da porta (h) = Abertura da porta (H) - 72mm

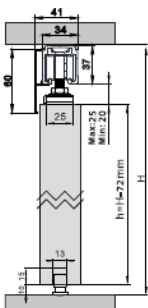

Topes / Stoppers / butées / Batentes

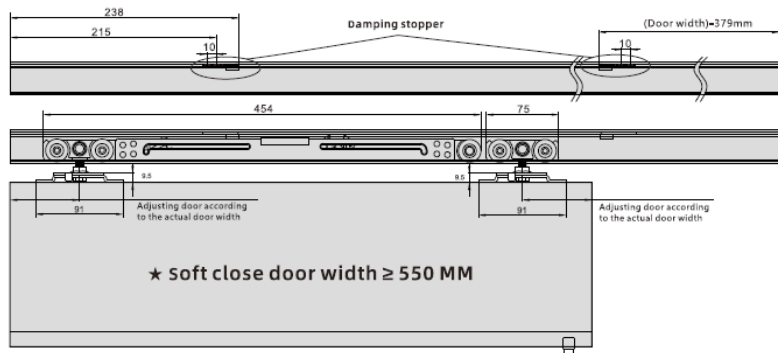

Anchura de la puerta ≥ 550 MM

Largeur de la porte ≥ 520 MM

Largura da porte ≥ 550 MM